

BPW Disc Brake Wear Limits

In order to operate a vehicle that is road safe, regular maintenance needs to be carried out. During maintenance, particular attention needs to be paid to the condition of the braking system. On disc braked axles the brake pads and discs are wearing parts and must be subjected to a visual inspection at regular intervals. Figure 1 gives a comparison of what a new brake pad and disc look like to a worn one. A new brake pad has an overall thickness of 30mm, while a worn brake pad has 2mm of friction material left (maximum permissible brake pad wear is 21mm). The allowable wear on a brake disc

is 4mm per side. Components that have reached their wear limit must be renewed.

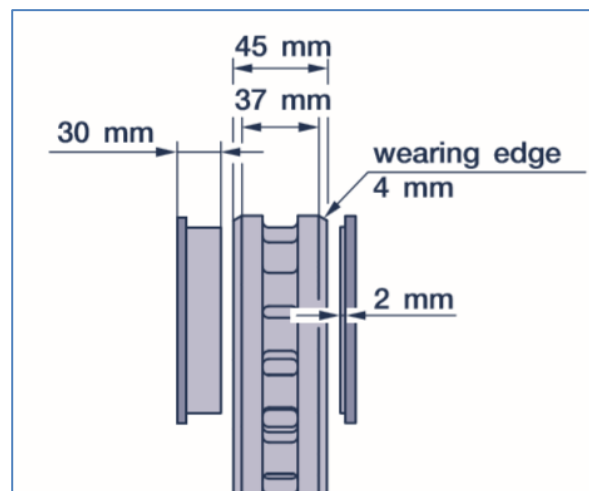

Figure 1: Wear limits of the brake pad in relation to the brake disc

Wear status of the brake pads

A good code of practice is to inspect the brake pads whenever the tyre pressure is checked. However, it is of utmost importance that the brake pads be inspected every three months. The thickness of the friction material of the pad must not be less than 2mm (this can be checked via a Vernier Calliper). Slight pitting on the edges is permitted, however, the pad must be renewed if it accounts for more than 10% of the pad surface (see Photo 1). This is because the size of the braking surface is reduced through the pitting which will cause a decline in brake effectiveness.



Photo 1: Edge pitting on the brake pad

Always inspect for wear on the brake pad hole. The allowable wear of the brake pad hole is 3mm, measured in any direction. The diameter of the brake pad hole measures 11mm when new and when worn, it measures 14mm.

Wear status of the brake disc

The brake disc must be inspected on a regular basis to check its remaining thickness and any possible damage on the braking surface. The remaining thickness of the brake disc must not be less than 37mm. Figure 2 shows the possible conditions of the brake rotor.

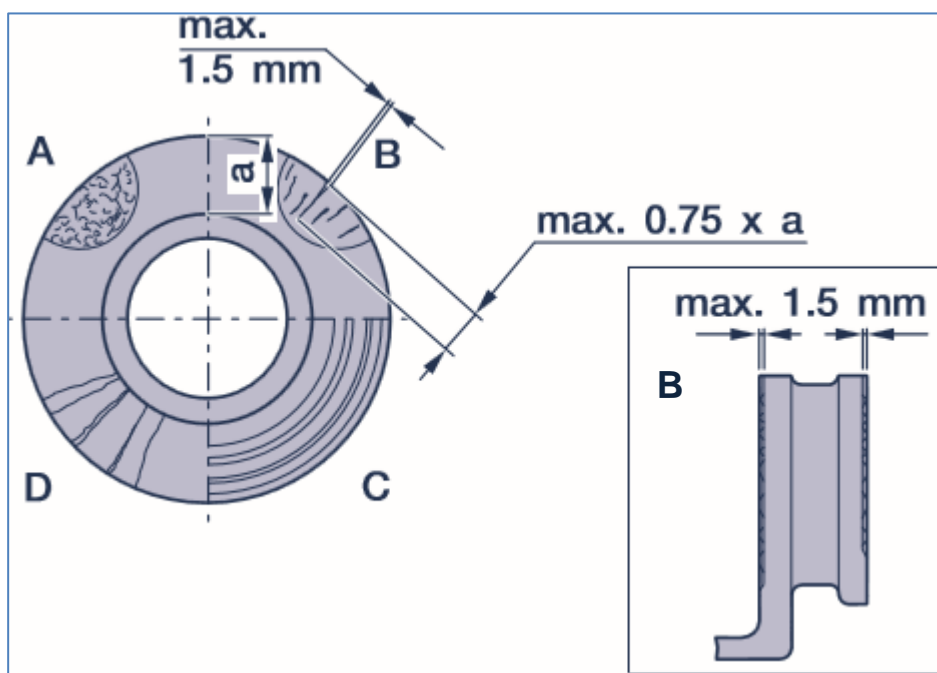

Figure 2: Wear status of the disc brake

- A. Network-type tears are permissible
- B. Radial cracks are permissible – up to a maximum of 1.5mm in width and depth and less than 75% of the surface width.
- C. Uneven surface (grooves) are permissible – less than 1.5mm are permissible
- D. Continuous cracks are not permissible, see Photo 2.



Photo 2: Continuous crack on brake disc

With surface conditions A – C the brake disc can continue to be used until the maximum wear limit is reached.